

---

## YSW400T1G 100 Specification

产品规格书 Specification		备注 Notes
标准型号 Standard model	YSW400T1G-100	基础型号 Basic model
拓展型号 Extended model		
拓展型号 Extended model		
拓展型号 Extended model		
拓展型号 Extended model		
拓展型号 Extended model		

修订记录 Revision record			
版本 Version	修订人 Reviser	描述 Description	日期 Date
REV002			2/21/2020

---

审核人 Checked

---

日期 Date

---

批准人 Approved

---

日期 Date

## \*1 规格参数 Specifications

1.1 基本性能指标 Basic Performance	
型号 Model	YSW400T1G-100 (including extended model)
型式 Type	低压腔式全封闭涡旋压缩机 LP Cavity Hermetic Scroll Compressor
应用 Application	热泵热水器 Heating pump
制冷剂 Refrigerant	R407C
排量 Displacement m <sup>3</sup> /h (cm <sup>3</sup> /rev)	42.5 (244.3)
制热量 Heating Capacity(W) <sup>(a)</sup>	51919
制冷量 Cooling Capacity (W) <sup>(a)</sup>	37920
输入功率 Input Power (W) <sup>(a)</sup>	13999
运行电流 Running Current (A) <sup>(a)</sup>	24.3
制热能效比(HeatingCOP) <sup>(a)</sup>	3.71
制冷能效比(CoolingCOP) <sup>(a)</sup>	2.71
电源 Power(V/PH/Hz)	380~420V/3~/50Hz
最低运行电压 Lowest Running Voltage (V)	342
最高运行电压 Highest Running Voltage (V)	462
堵转电流 LRA (A)	148.5
最大运行电流 MOC <sup>(b)</sup> (A)	31.6
额定转速 Rated Speed (r/min) <sup>(c)</sup>	2900
压缩机重量 (含油) (kg) Compressor Weight With Oil	90
润滑油型号 Oil type	POE (32cst)
初次注油 First Charge(L)	3.4
重新注油 Recharge(L)	3.25
油循环率 Oil Circulation (%) <sup>(f)</sup>	≤1
额定噪音(声功率级) <sup>(g)</sup> (dB) Rated Sound (Sound Power)	75
运行范围内最大运行噪音 (声功率级) (dB) Max Running Sound (Sound Power)	80
最大振动位移值 Peak-Peak (mm) <sup>(h)</sup> Max Vibration Displacement Peak-Peak	≤0.12
最大水分含量 Maximum Moisture (mg)	≤500
最大杂质含量 Maximum Impurity (mg)	≤100
最低启动电压 LVS (V) <sup>(d)</sup>	323
最大负载运行时最低电压 MOV (V) <sup>(e)</sup>	342
启动电容 μf/V Start Capacitor	-
启动继电器 Start Relay	-
运行电容 μf/V Run Capacitor	-

1.2 电气参数 Motor Parameters	
电机形式 Motor Type	感应电动机 Induction motor
电机级数 Pole	2
电机绝缘温度℃ Motor Insulation Temperature	130 (B Class)
端子之间电阻 UV(CS) Terminals Resistance UV(CS) (Ω, 25℃)	0.7 ( ± 10%)
端子之间电阻 UW(CR) Terminals Resistance UW(CR) (Ω, 25℃)	0.7 ( ± 10%)
端子之间电阻 VW(SR) Terminals Resistance VW(SR) (Ω, 25℃)	0.7 ( ± 10%)
绝缘耐压 Insulation Voltage (V)	2000
泄露电流 Leakage Current (mA)	≤5
绝缘电阻 Insulation Resistance (MΩ)	≥20
接地电阻 Ground Resistance (Ω)	≤0.1
1.3 安全运行限制 Safe Running Conditions	
气密性检漏压力 Air tightness Test (Mpa)	3.8
最大运行压力 Highest Running Pressure	
高压侧 High Side (Mpa) 低压侧 Low Side (Mpa)	H3.0/L2.0
压缩机内空余容积(不含油)Spare volume (without oil)	
高压侧 High Side(L) 低压侧 Low Side (L)	H0.9/L6.3
最大冷媒充注量(kg)	2.5x 油量 Oil Weight
排气温度上限 Max Discharge Temperature	125℃
启停周期 Compressor Start-off Revolution	Above 3min

性能指标工况说明 Running Condition Notes:

工况 Condition	工况说明 Notes
a	第一额定点 Test Condition: First Rated Running Point
b	最大负载工况@90%额定电压 Maxload condition@90%rated voltage
c	第一额定点 Test Condition: First Rated Running Point
d	排气压力, 吸气压力=40℃制冷剂饱和压力 Discharge & Suction Pressure= Refrigerant 40℃ Saturation Absolute Pressure
e	最大负载工况 Maxload condition
f	第一额定点 Test Condition: First Rated Running Point

g	第一额定工况，A 加权声功率级平均值 First Rated Point, A class average sound power
h	第一额定工况，运行时压缩机外壳法向最大位移 First Rated Point, Maximal Shell Running Displacement Under Normal Direction

\*3 额定工况，性能与噪音值需在额定试验工况运行 48 小时磨合后进行测试  
Rated Condition, Performance And Sound Test Needed 48hrs Break In Running

序号 SN	工况说明 Notes	最大负载工况 Max load condition
额定工况 Rated condition ET/CT/SH/SC/AT°C	5/55/11.1/8.3/35°C	15/70/11.9/8.3/46.1°C
制冷/制热量偏差 Capcitiy deviation	Min -5%	-
功率偏差 Power deviation	Max +5%	-
能效偏差 COP deviation	Min -5%	-

\*4 内置保护 Internal Protection Parts

保护方式 Protect method	配置 Configuration	数值 Value
内置过载保护器 Internal protector Protection	有 With	-
内置压力保护器 Internal Pressure Release Valve Protection	有 With	400-450 (PSI)

\*5 压缩机附件 Standard Configuration:

YSW400T1G-100			
附件 Accessory	名称 Description	料号 P/N	数量 PCS
1	脚垫 Grommet	070-0020-00	4
2	平垫片	GB/T95 10	8
3	锁紧螺母	GB /T 889.1 M10	8
4	弹性垫片	GB 93-87 10	8
5			

\*6 压缩机运行范围 Compressor Running Envelop

6.1 压缩机运行范围

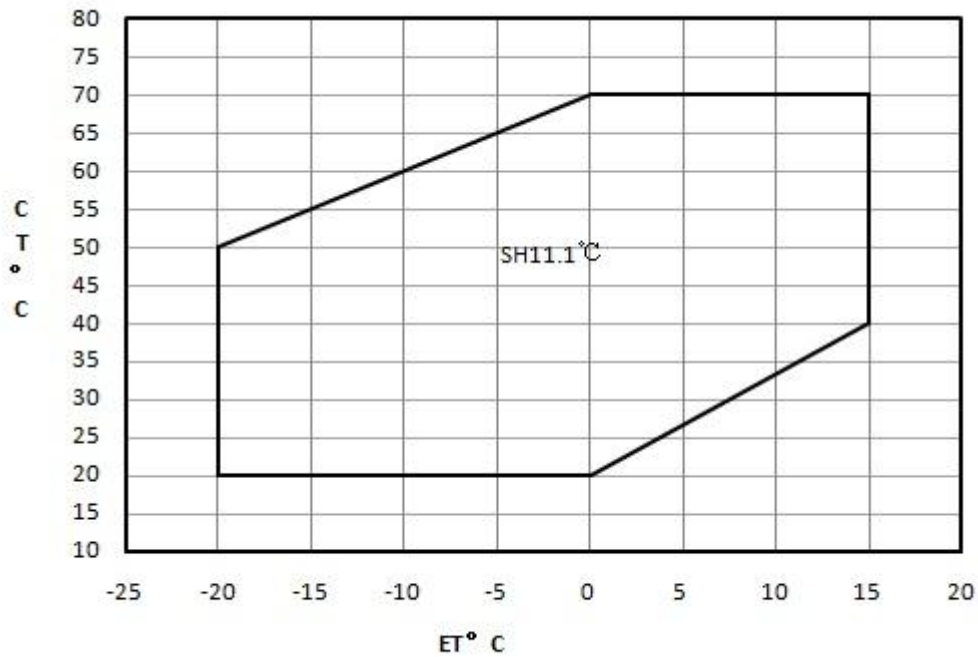

6.2 喷气增焓控制逻辑（仅适用于喷气增焓机型）

EVI control logic(only for EVI modles)

- 建议系统的冷凝过冷度 5°C
- Recommend system subcooling 5°C
- 当压缩机排气温度≤95°C，控制喷射过热度=5°C
- DLT≤95°C,control superheat of injecting=5°C
- 当压缩机排气温度>95°C，控制压缩机排气温度=95°C
- DLT>95°C,control DLT=95°C
- 最大喷射压力不超过 20bar.a
- Max injecting pressure≤20bar.a

\*7 压缩机性能参数表 Compressor Performance Sheet

7.1 性能表 performance table

基于运行范围内的吸气过热，热泵/空调系列过冷度 8.3°C，冷藏/冷冻系列过冷度 0°C。

Superheat based on envelop, subcooling of heating pump and air condition is 8.3°C ,subcooling of refrigerantion is 0°C.

Type	Condition	-20	-10	0	10
HCap W (CCap+Power)	50	25598	34839	46589	61666
	40	25745	35510	48111	64368
	30	26054	36421	49951	67468
CCap W	50	15138	22952	33861	48137
	40	16672	25479	37386	52666

	30	18307	27963	40725	56868
Power W	50	10460	11887	12728	13529
	40	9073	10031	10725	11702
	30	7747	8458	9226	10600

## 7.2 多项式十系数 Ten coefficients of polynomial

压缩机的制冷量和功率参数可以通过多项式进行全运行范围工况在标准过热和过冷度下的计算。

Capacity and power of compressor can be calculated by ten coefficients of polynomial at standard superheat and subcooling.

多项式表达式 Expression	$z = p_0 + p_1 \cdot x + p_2 \cdot y + p_3 \cdot x^2 + p_4 \cdot x \cdot y + p_5 \cdot y^2 + p_6 \cdot x^3 + p_7 \cdot x \cdot y^2 + p_8 \cdot x^2 \cdot y + p_9 \cdot y^3$		
物理量解释 Description	z:制冷量 W 或功率 W; z:Capacity W or Power W 特别说明: 制热量 W=制热量 W+功率 W Notes: Hcap W= Ccap W+ Power W x:蒸发温度℃ x:ET℃ y:冷凝温度℃ y:CT℃ p0~p9:多项式系数 p0~p9:coefficients of polynomial		
制冷量系数 Ccap factor	数值 Value	功率系数 Power factor	数值 Value
p0	51127.331457	p0	7712.189519
p1	1612.85695	p1	301.631179
p2	-386.121355	p2	-23.201097
p3	16.99257	p3	7.855629
p4	-3.602316	p4	-10.112022
p5	2.058831	p5	2.434108
p6	0.045616	p6	0.091331
p7	-0.003118	p7	-0.161011
p8	-0.071233	p8	0.110773
p9	-0.024859	p9	0.000723

说明: 多项式的系数是基于一定样本数据的拟合结果, 其数据可供压缩机选型参考, 但无法完全替代用户的测试。

Notes: Coefficients of polynomial is based on the fitting results of some sample data, which can be used as a reference of compressor selection, but can not completely replace customer 's test.

---

**\*8 注意事项 Notes**

1. 压缩机不得抽真空、真空运行、压缩空气、空转或逆转；

The compressor should not be used to be operated under vacuum, compress air, run without load or reverse;

2. 压缩机吸排气塞打开后，放置时间不超过 15 分钟；

The compressor should not be opened in the atmosphere for more than 15 minutes;

3. 压缩机连续运行需 10 分钟以上，停机再次启动间隔 3 分钟以上，不得频繁启停，以免压缩机内润滑油随冷媒被大量地排出压缩机；

The compressor continuous running time should be more than 10minutes, the duration between two start-ups shall exceed three minutes, the compressor should not start/stop frequently to avoiding oil being pumped together with the refrigerant;

4. 压缩机启动前，排气压力-吸气压力 $\leq 0.3\text{Mpa}$ ；

Before starting, discharge pressure – suction pressure $\leq 0.3\text{Mpa}$ ;

5. 运行电压范围，应在额定电压的 $\pm 10\%$ 以内；

The running voltage shall be within  $\pm 10\%$  of the rated voltage;

6. 低温工况的应用，由于大量冷媒可能会迁移到压缩机腔体内，沉积在压缩机底部，对于压缩机的启动会造成润滑及回油不良，建议加装曲轴加热装置；

In low temperature application, because lots of refrigerant may migrate to the compressor cavity, deposit at the bottom of the compressor, it may cause the problem of lubrication and oil return, it is better to install the crankshaft heating device;

7. 系统应配置必要的压力、温度、过流、缺相等保护及回油装置等；

The system should set basic protection of pressure, temperature, over-current, phase-loss and oil return device etc.

8. 压缩搬运，安装过程中不得平放、倒置；

Do not put the compressor horizontally or put it upside down.

\*10 压缩机外形图 Compressor Outline Dimensions

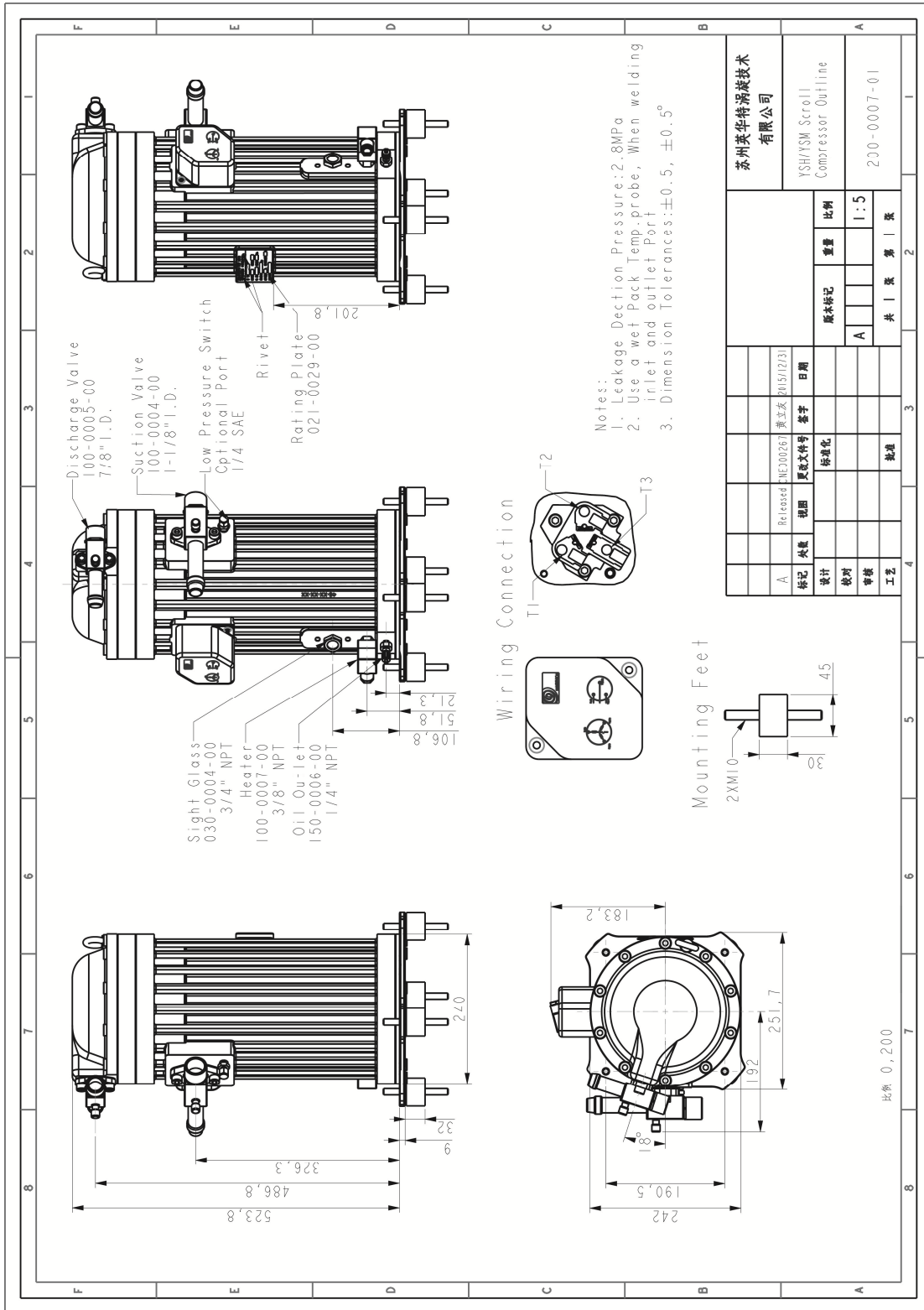



---

\*11 单相压缩机接线图 Single phase compressor wiring diagram

仅适用于单相 only for single phase

