

Ref. NO.	LGACC-130314-073
Issued Date	2013.03.14
Rev. NO.	Rev. 0
Rev. Date	-

1.Specification

1.1 Compressor

1	Model Name	GPT407PAA
2	Compressor Type	Hermetic Motor Compressor
3	Compression Type	Rotary Type (Rolling Piston Type)
4	Application	Refrigeration system (Cooling & Heating)
5	Refrigerant	R410A
6	Safety Approval	VDE
7	Oil / Oil Charging Amount	PVE(FVC68D)or Equivalent / 800 cc
8	Displacement	40.7 cm ³ / rev
9	Painting	Black Color Paint
10	Net Weight (Including Oil)	23.7 kg
11	Suction Tube I.D	Φ 16.0 mm
12	Discharge Tube I.D	Φ 9.7 mm

1.2 Motor

Motor Type / Starting Type	Single Phase Induction Motor / PSC	
Pole / Rated Output	2 Pole / 2800 Watts	
Power Source	1Ph – 220-240 Volts – 50Hz	
Rated Revolution	2901 rpm	
Insulation Class	E Class	
Windings Resistance (at 75 °C)	Main	1.22 ± 7% Ohms
	Sub	3.14 ± 7% Ohms
Locked Rotor Ampere	82 A (at 240 V)	

Ref. NO.	LGACC-130314-073
Issued Date	2013.03.14
Rev. NO.	Rev. 0
Rev. Date	-

1.3 Wiring diagram

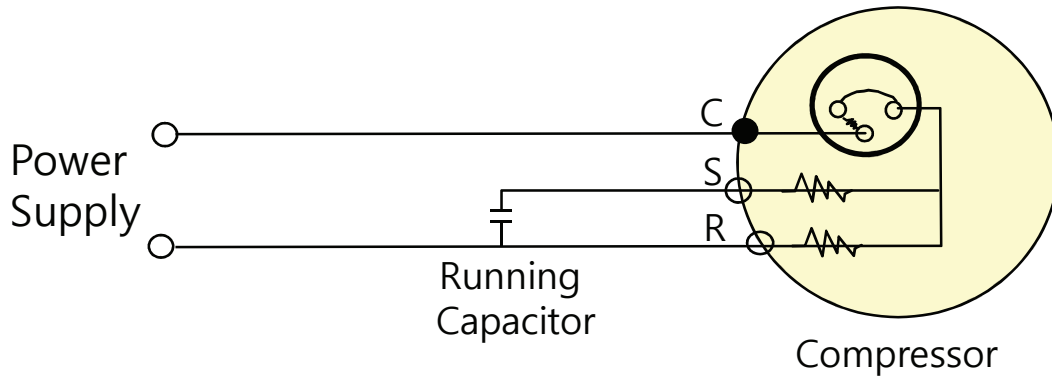

※ Make Sure to connect right way same with the wiring diagram.

1.4 Electrical Component

Running Capacitor	60 MFD / 450 VAC
Over Load Protector	Internal (SENSATA)

1.5 Performance

Voltage		At 220 V	At 240 V
Cooling Capacity (-5% ↑)	[BTU/h]	34,800	35,100
	[W]	10,199	10,287
Power Input (+5% ↓)	[W]	3,551	3,695
EER (-5% ↑)	[BTU/Whr]	9.8	9.5
	[W / W]	2.87	2.78
Running Current	[A]	16.5	16.8

☞ Rated Conditions (ASHRAE-T Condition)

Cond. Temp. : 54.4 °C (130 °F)

Evap. Temp. : 7.2 °C (45 °F)

Return Gas Temp. : 35.0 °C (95 °F)

Liquid Temp. : 46.1 °C (115 °F)

Ambient Temp. : 35.0 °C (95 °F)

Ref. NO.	LGACC-130314-073
Issued Date	2013.03.14
Rev. NO.	Rev. 0
Rev. Date	-

1.7 Minimum Starting Voltage

Cold Start - Temp. Condition : 35°C - Balanced pressure : Pd – Ps ≤ 0.5 kgf/cm ²	187 Volts Max.
---	----------------

1.8 Voltage Range

at Standard Condition	187 ~ 264 Volts
at Overload Condition	198 ~ 264 Volts

☞ Test Conditions

	Standard Condition	Overload Condition
Con. Temp (°C)	54	65
Eva. Temp (°C)	7	13
Return Gas. Temp (°C)	35	25
Ambient Temp (°C)	35	43

1.9 Others

Leak Tight Pressure	High Pressure Side	42kgf / cm ² G
	Low Pressure Side	-
Hydrostatic strength Pressure	High Pressure Side	170 kgf / cm ² G
	Low Pressure Side	69 kgf / cm ² G
Insulation Resistance (with 500V D.C Mega Tester)		50 MΩ Min.
Withstand Voltage		At 2,200 V / 1 Sec. Leakage Current is less than 5 mA
Residual Moisture (Karl Fisher Method)		100 mg Max.
* Residual Impurities		70 mg Max

*) Each part was measured separately

Ref. NO.	LGACC-130314-073
Issued Date	2013.03.14
Rev. NO.	Rev. 0
Rev. Date	-

3. Operating Limit

3.1 Operation Range

Discharge Pressure	[kgf / cm ² G]	42 Max
Suction Pressure	[kgf / cm ² G]	3.0 ~ 12
Discharge Pipe Temp.	[°C]	115 Max.
Motor Coil Temp.	[°C]	130 Max.

Pressure Temp.
(kg/cm² G) (°C)

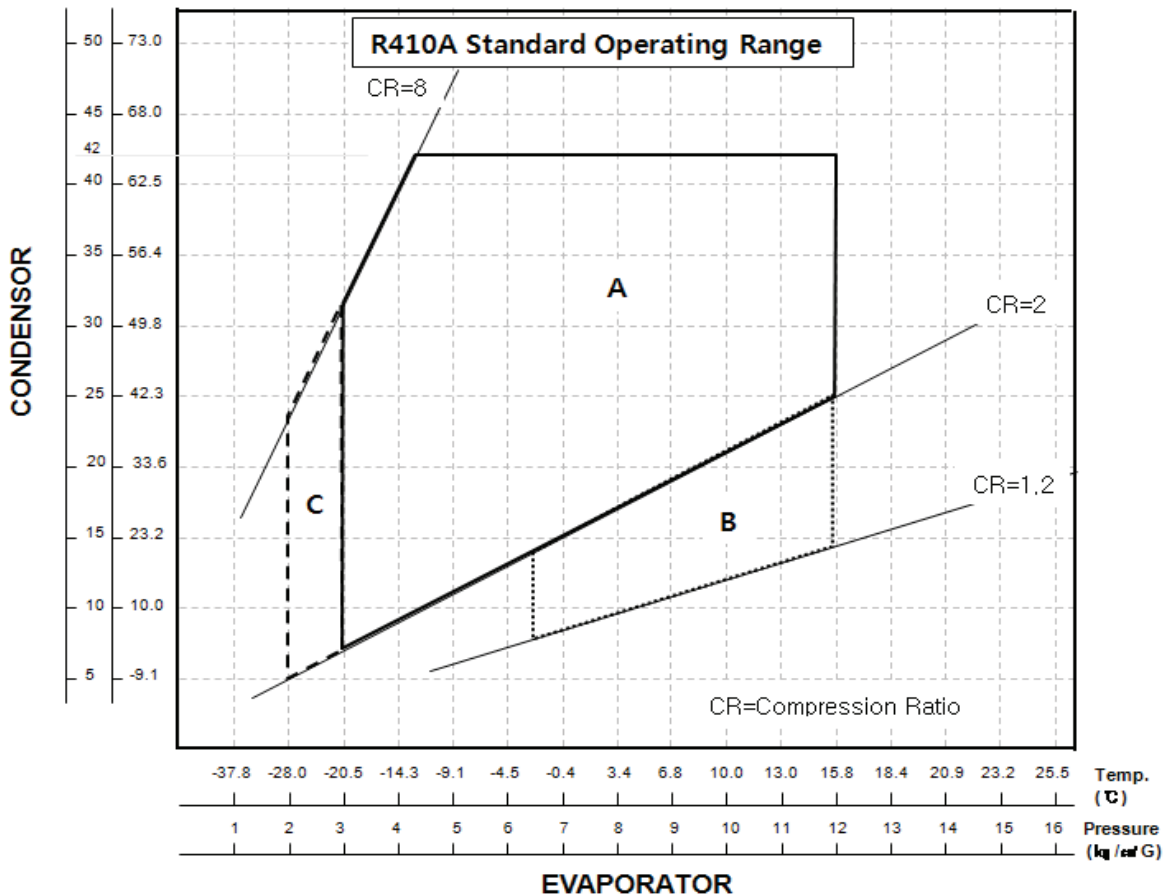

Area A : Normal Operating Zone

Area B : High Density Flow Zone
-During starting within 3 minutes

Area C : Low Pressure Zone(defrosting & re-starting)
-Running time less than 3 minutes.
-Should be checked liquid back

Ref. NO.	LGACC-130314-073
Issued Date	2013.03.14
Rev. NO.	Rev. 0
Rev. Date	-

3.2 Application Limit

Refrigerant Charge Limit	[Cooling System] Max 3,000g [Heating System] Max 2,060g (Charge limit depends on Oil Dilution Rate ^{*note 1} & accumulator 'K')
Liquid Refrigerant Back	System should be designed not to allow the liquid to go back to compressor which cause knocking noise , current increase or undesirable vibration and make short compressor life time.
Δ T : Temp. Difference	Δ T = Case Bottom Temp. - Condensing Temp. It must be kept Δ T ≥ 5°C
Pressure Difference in Operating	The Pressure difference in operating shall be 5.0kgf/cm ² or more, but 3 minutes starting excluded.
ON/OFF Operation	Each cycle should be at least 6 minutes (ON Time : at least 3 minute , OFF Time : at least 3 minutes)
Pressure Difference at Starting	When starting, discharge pressure is balanced with suction pressure. (Pd – Ps ≤ 0.5 kgf/cm ²)
Tilt in Operation	The allowable tilt of the compressor in operation shall be 5° or less.
System Accumulator	The Accumulator volume should be enough to cover 50% of maximum system refrigerant volume. Ratio coefficient 'K' should be over 0.6(heating system) or 0.4(cooling system) $K = \frac{\text{Volume of Accum. (Comp+System)} \times \text{Specific gravity of Refrigerant}}{\text{Charged Weight of Refrigerant}}$ <ul style="list-style-type: none"> ※ Effective volume of compressor accumulator = 1033 cm³ ※ Specific gravity of refrigerant (R410A) = 1.20 g/cm³ (at 20°C) <p>If coefficient "K" does not meet recommendation, refrigerant system must check liquid back phenomenon at accumulator.</p>
Protecting Reverse Operation	The compressor must be operated by proper voltage in accordance with the frequency without reverse revolution condition. The reverse revolution condition can be avoided by just keeping right order of phase supplied power source.

Ref. NO.	LGACC-130314-073
Issued Date	2013.03.14
Rev. NO.	Rev. 0
Rev. Date	-

3.2 Application Limit

Frequency Range	Rated Frequency $\pm 2\%$
Pipe Stress	Don't allow any force on discharge & suction pipe . The piping stress must be less than 300kgf/cm ² at starting and stopping. And less than 153kgf/cm ² at running.
Oil Level	It must be checked oil level by the compressor with sight glass we supply. And oil level must be kept over guide line level **note 2. at any condition.
Protection device	Refrigeration system must has the compressor protection device like over pressure, high temperature, sensing locked pump in the controller. When starting & running fail by abnormal overload, controller must be able to cut off power of compressor before motor burn out.
	An earth terminal should be installed to prevent electrical accidents.
Pump down refrigerant	If pump down time is too long, compressor can be damaged due to excessive temperature increase or poor lubrication. Guideline of pump down process. - Time : less than 30 seconds - Suction Pressure : It should not run under below 1kgf/cm ² G. And before closing a service valve, compressor running for more than 5 minutes is recommended.

※ If gas charge amount of refrigerant specified is exceeded, both parties should discuss the matter to determine compressor specification. (accumulator volume, lubricating oil amount) and system specifications (crank case heater, oil separator , additional accumulator, etc)

* Effective Period of This Document *

This document will be effective after LG's receipt with your authorized signature. When design modification is approved by the customer, the current document is unavailable.

Ref. No.	LGACC-130314-073
Issued date	2013.03.14
Rev. No.	Rev. 0
Rev. Date	-

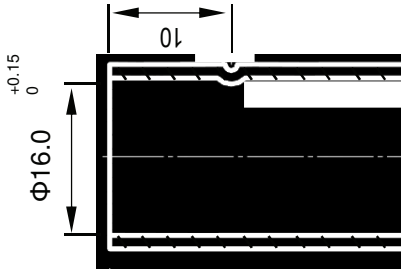
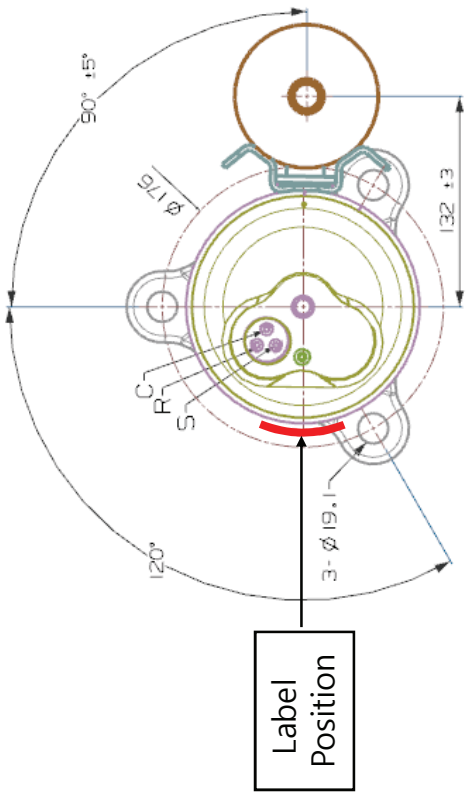

Detail of Discharge Tube

Detail of Suction Tube

NOTES

1. PAINTING : BLACK PAINT (ELECTRO DEPOSITION)
2. OIL : FVC 68D or EQUIVALENT 800 cc CHARGED
3. NITROGEN CHARGED AFTER DEHYDRATION
4. UNIT : mm

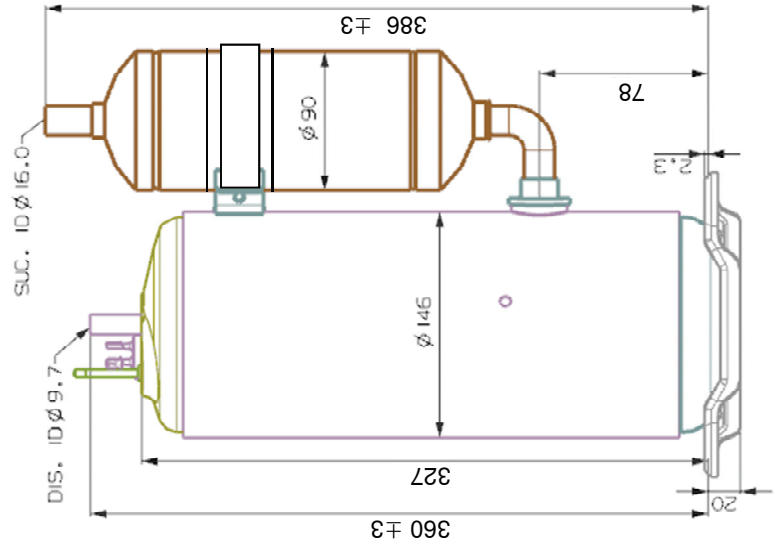

UNIT	mm	SCALE	N / S
DES. ENGR.	CHF. ENGR.	COMP. OUT LINE	
Mar. 14. 2013	Mar. 14. 2013	GPT407PAA	
S. M. KIM	T. Y. NOH		
LG Electronics Inc. EC Business Unit	CUSTOMER EMBRITAL		