

Ref. NO.	-
Issued Date	-
Rev. NO.	-
Rev. Date	-

1.Specification

1.1 Compressor

1	Application	Cooling and Heating with BLDC Inverter System
2	Compressor Type	Hermetic Motor Compressor
3	Pump Type	Twin Rotary (Two Cylinder Rolling Piston Type)
4	Displacement	44.2 cm ³ / rev
5	Refrigerant	R410A
6	Oil / Oil Charging Amount	FVC68D / 1,300 cc
7	Painting	Black Color Paint
8	Net Weight (Including Oil)	20.2 kg
9	Suction Tube I.D	Φ 16.0 $\begin{matrix} +0.15 \\ 0 \end{matrix}$ mm
10	Discharge Tube I.D	Φ 12.75 $\begin{matrix} +0.16 \\ 0 \end{matrix}$ mm

1. Specification

1.2 Motor

Ref. NO.	-
Issued Date	-
Rev. NO.	-
Rev. Date	-

Motor Type / Starting Type	BLDC Motor / DC Inverter Starting	
Pole / Rated Output	6 Pole / 4,000 Watts	
Power Source	Brushless Inverter (3Φ 280 Volts)	
Winding type	Concentrated Winding	
Insulation Class	E Class	
Windings Resistance (at 75 °C)	U-V	0.438 Ohms
	V-W	0.438 Ohms
	W-U	0.438 Ohms
BEMF (V)	52.8 Vrms / k rpm (Line-to-Line)	

Current(A)	2	6	10	14
Lmin(mH)_Line-to-Line	6.22	6.43	6.33	6.09
Lmax(mH)_Line-to-Line	11.92	11.52	10.75	10.03

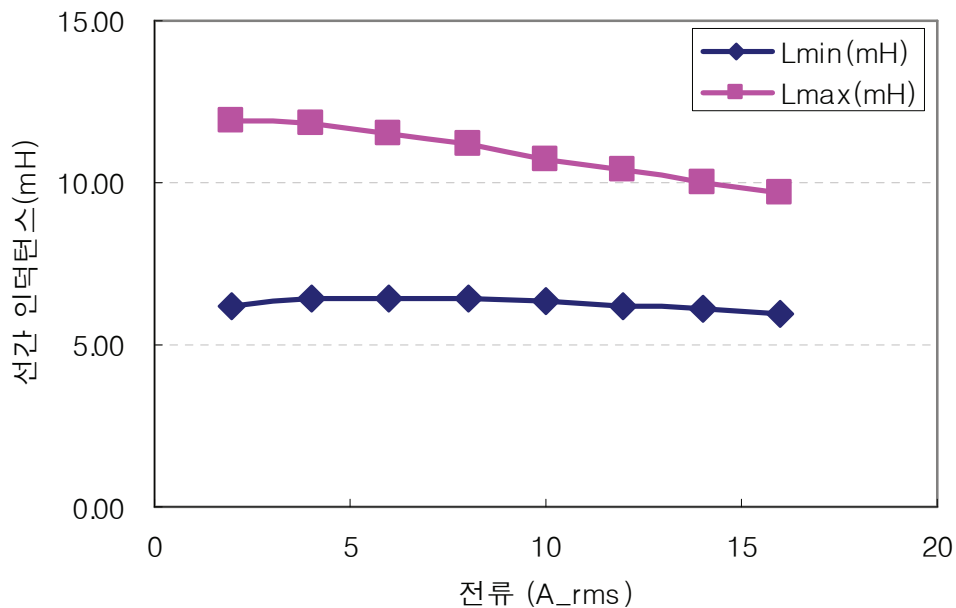

Ref. NO.	-
Issued Date	-
Rev. NO.	-
Rev. Date	-

1.3 Wiring diagram

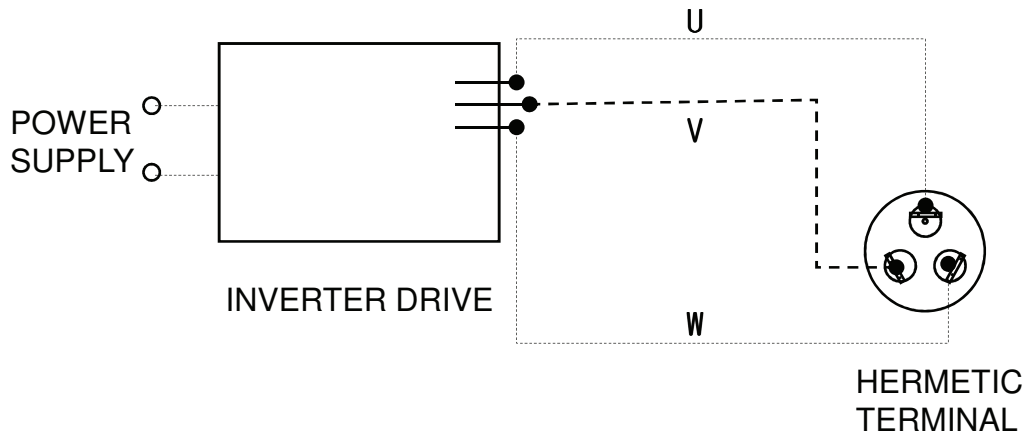

1.4 Performance

※ Electric source

DC Link Voltage : 380 V , 180° Sine Wave Current Charge (Designed by LGE)

		60Hz
Cooling Capacity (-5%↑, Z Value : 4.0↑)	[BTU/h]	47,500
	[kW/h]	13,921
Power Input (+5%↓, Z Value : 4.0↑)	[watts]	4,241
EER (-5%↑, Z Value : 4.0↑)	[BTU/w · hr]	11.2
Running Current	[A]	14

☞ Rated Conditions (ARI Condition)

Cond. Temp. : 54.4 °C (130 °F)

Evap. Temp. : 7.2 °C (45 °F)

Return Gas Temp. : 18.3 °C (65 °F)

Liquid Temp. : 46.1 °C (115 °F)

Ambient Temp. : 35.0 °C (95 °F)

Ref. NO.	-
Issued Date	-
Rev. NO.	-
Rev. Date	-

1.6 Others

Leak Tight Pressure	High Pressure Side	42 kgf / cm ² G
	Low Pressure Side	-
Hydrostatic Strength Pressure	High Pressure Side	170 kgf / cm ² G
	Low Pressure Side	80 kgf / cm ² G
Insulation Resistance (with 500V D.C Mega Tester)		50 MΩ Min.
Withstand Voltage		At 2,200 V / 1 Sec. (Sin Wave) Leakage Current is less than 5 mA
Residual Moisture (Karl Fisher Method)		150 mg Max.
* Residual Impurities		70 mg Max

*) Each part was measured separately

1.7 Revolution Range (By standard DC Inverter)

Operating Range	15 ~ 100 rps
Rated Condition	30 ~ 90 rps
Max Load Condition	40 ~ 80 rps

* Condition

	Rated Condition	Max Load Condition
Con. Temp(°C)	55	65
Eva. Temp(°C)	7	12
Return Gas. Temp(°C)	35	25
Ambient Temp(°C)	35	35

Ref. NO.	-
Issued Date	-
Rev. NO.	-
Rev. Date	-

3. Operating Limit

Application Limit

Discharge Pressure	[kgf/cm ² G]	42 Max.
Suction Pressure	[kgf/cm ² G]	2.4 ~ 14
Discharge Pipe Temp.	[°C]	115 Max.
Motor Coil Temp.	[°C]	130 Max.
Max load current	[A]	23 Max.

Pressure Limit

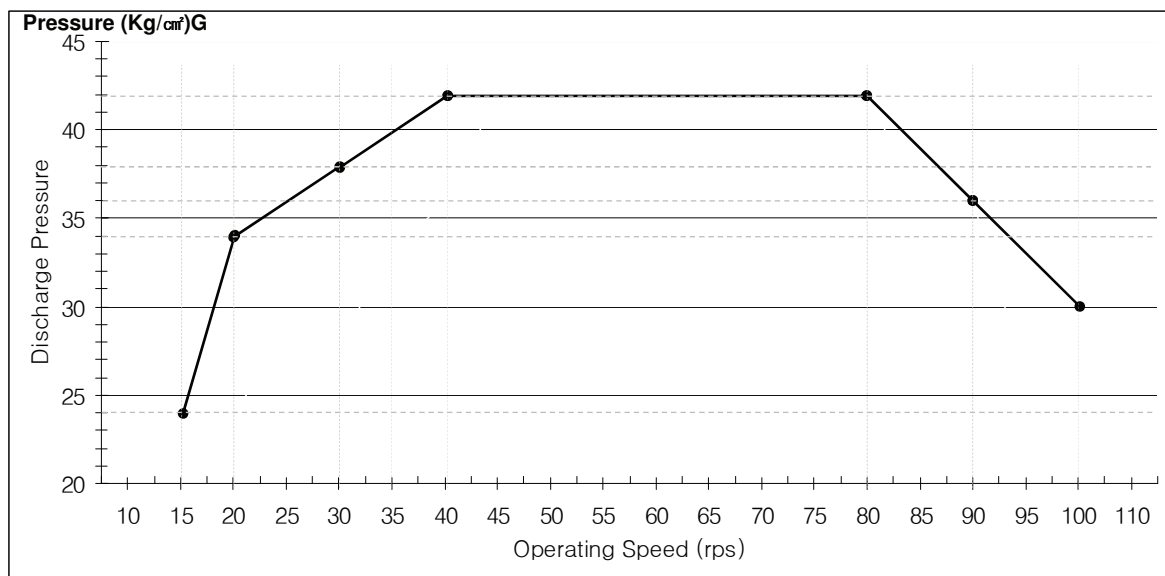

Ref. NO.	-
Issued Date	-
Rev. NO.	-
Rev. Date	-

Pressure Temp.
(kg/cm²) G (°C)

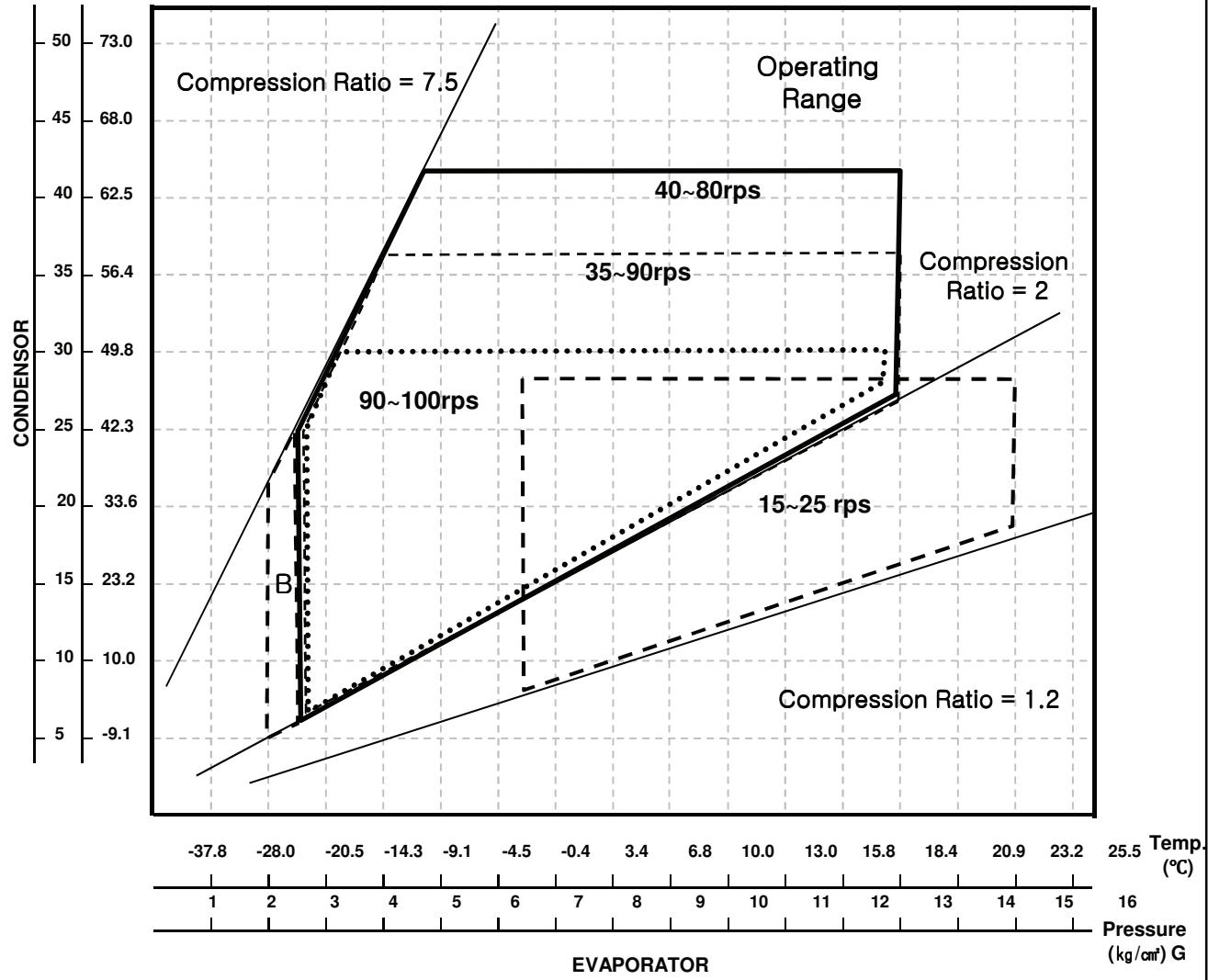

- In case of B Area,
- less than 3 min. at defrosting and restarting after defrosting
 - Motor wire temperature less than 130°C
 - Do not occur liquid refrigerant back
 - Must keep oil level guide line.

Ref. No.	-
Date	-
Rev. No.	-
Rev. Date	-

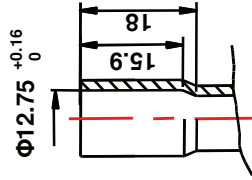
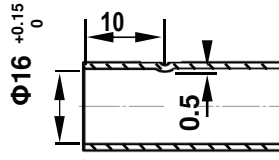
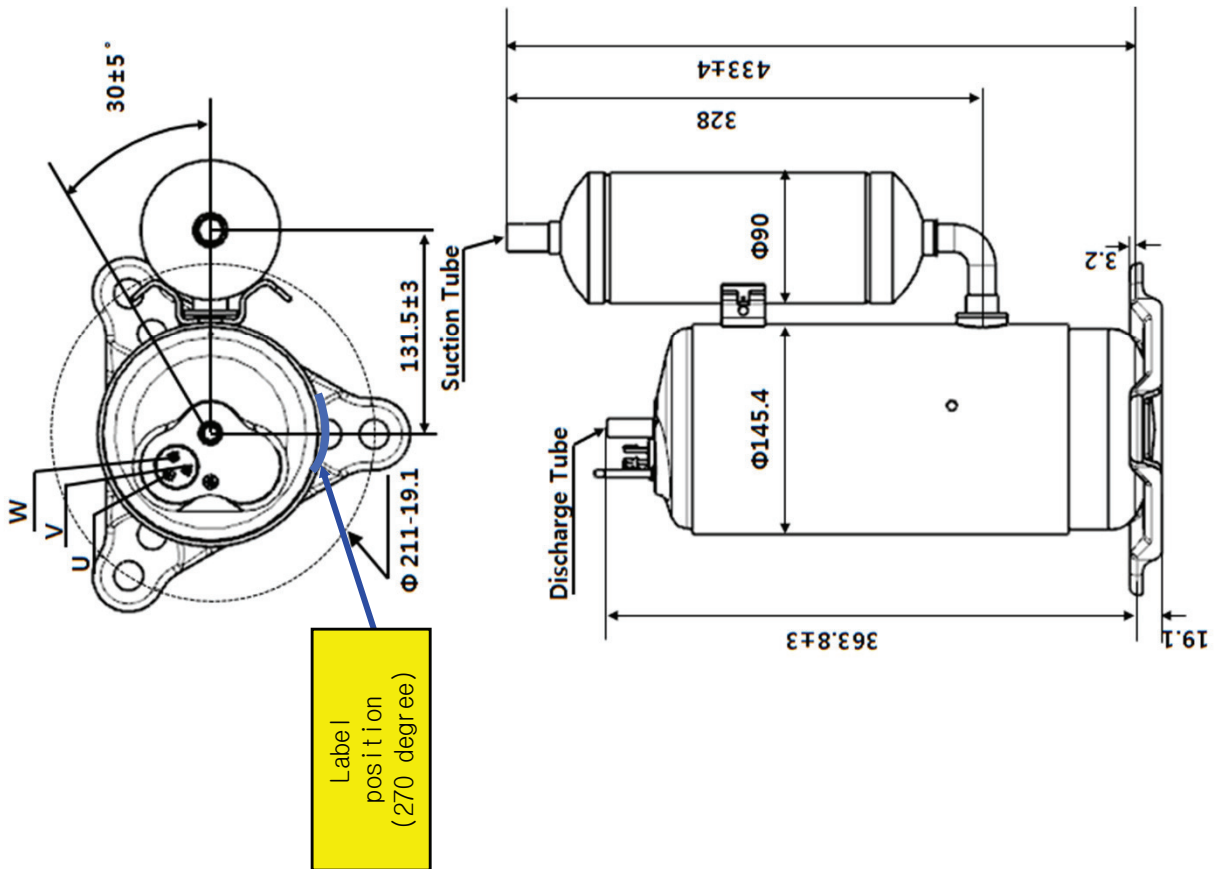

Detail of Discharge Tube

Detail of Suction Tube

NOTES

1. PAINTING : BLACK PAINT (ELECTRO DEPOSITION)
2. OIL : FVC68D 1300 ±10% cc CHARGED
3. NITROGEN CHARGED AFTER DEHYDRATION
4. DIMENSIONS ARE mm UNITS

UNIT	mm	SCALE	N / S
DES. ENGR.	J. G. LEE	CHF. ENGR.	Dec.22. 2011 T.Y. NOH
LG Electronics Inc. C&M BU		CUSTOMER EMB BU	
COMP. OUT LINE			
GPT442MBB			